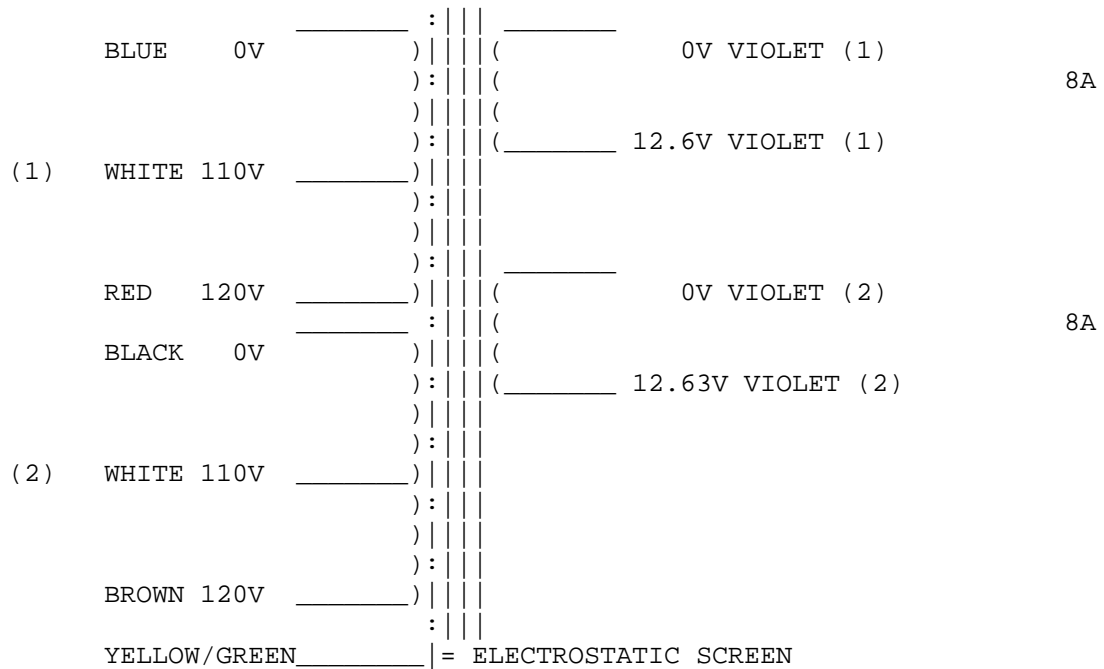

9979

For 240V: Join RED & BLACK. Use BLUE & BROWN
(Isolate both WHITES separately)

For 120V: Join BLUE & BLACK 0V and join RED & BROWN 120V.
(Isolate both WHITES)

For 110V: Join BLUE & BLACK 0V and join both WHITES 110V.
(Isolate RED & Isolate BROWN)

* FOR PRIMARY WINDING WITH SOLID CORE WIRE AND SLEEVING

If the WHITE leads are cut short please ensure the TWO wires inside the sleeving are joined together in BOTH cases.

The solid wire inside the sleeving is coated with polyurethane and needs to be stripped away and tinned if the leads are shortened. For secondary windings with solid core leads please follow the same process.

FOR FLEXIBLE LEADS PRIMARY AND SECONDARY:

Just cut short and isolate any spare connections

NOTE: A certain amount of mechanical hum is prevalent in mains transformers and can be amplified when bolting to your metal work. Therefore you may find a small rubber gasket or similar material is worth fitting to quieten this hum to its' minimum, but please ensure the frame is grounded to the supply safety earth.